

## DESIGN TIPS FOR SELECTING SENSING PROBES

### APPLICATION

Admittance sensing probes inserted into a container provide an effective and reliable way to sense the position of liquids, solids, and interfaces. Some of the advantages are:

- Operates at high or low process pressures; hard vacuum to 10,000 PSI (-1 to 700 BAR)
- Operates at high or low process temperatures; -460 to +1000°F (-273° to +550°C)
- Insensitive to specific gravity; easily measures water/hydrocarbon interfaces
- Requires only a small tank connection
- Push button calibration, even while in service
- Corrosion proof, if all PTFE or ceramic wetted
- Very high reliability; long service life
- Useful on most process materials
- No moving parts; no periodic maintenance

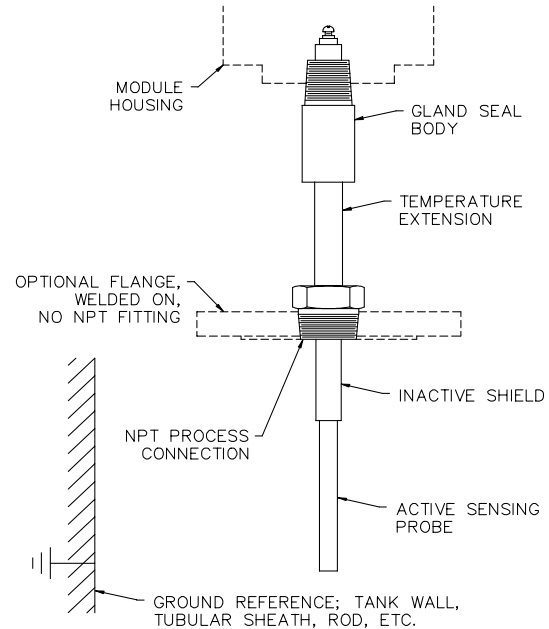

### SELECTING SENSING PROBES FOR LIQUID SERVICES

#### PROBES FOR CONDUCTIVE LIQUIDS

It is not necessary to know the dielectric constant of a liquid if it is conductive. The effective dielectric constant is so high for all conductive liquids that all of them produce a maximum pulse wave signal response. This fact allows the selection of a probe from the probe data sheet without knowing the actual dielectric constant of the liquid. An insulation jacket on the sensing probe is required.

#### PROBES FOR NON-CONDUCTIVE LIQUIDS

Liquids are "nonconductive" if they have an electrical resistance of 100,000 Ohms (DC) from probe to ground. Pulse wave instruments detect level by measuring the ability of the space between the sensing probe and reference ground to conduct wave energy.

#### TUBULAR GROUND REFERENCE

Sheathed probes are required for proportional measurement of horizontal cylindrical tanks. The sheath is the ground reference, is straight, has a linear gain factor, and produces a linear output signal as the liquid level changes. An open probe will produce a nonlinear signal in this application because the distance to the ground reference is nonlinear. This nonlinearity does not affect blind alarms because they are set referenced to a signal level produced at a particular fluid level.

#### PROBES FOR PRESSURE LIQUIFIED GASES

Butadiene and sulfur dioxide are examples; open probes are usually not suitable for this service because the density (and consequently the Dc) of the compressed vapor becomes large when compared to that of the liquid. Types with a concentric ground reference sheath, with inherent high gain, are usually preferred choices. Probes are selected based on the dielectric constant difference between the vapor and liquid.

$$\text{Net Dielectric Constant} = \text{"Dc" of the Liquid} \times \left( 1 - \frac{\text{Density of Vapor}}{\text{Density of Liquid}} \right)$$

#### WORKING TEMPERATURE LIMITS

The working process temperature limits can be made greater than the module ambient temperature limits by adding a cooling extension and/or by remoting the electronics module. Note that the probe seal and insulation materials are also limiting factors.

The following table is based on PTFE gland seals; except for the "TFE" cable. The limitation shown under "TFE" is based on the use of ceramic gland seals.

Probe Temperature Extension Length	Limit with Integral Electronics Module	Remoted Electronics, Cable Limit; C/F if higher	
		"PE" cable	"TFE" cable
0"	-40 to +200°F	-60 to +200°F	-125 to +450°F
3" (75mm)	-50 to +255°F	-80 to +225°F	-175 to +525°F
6" (150mm)	-60 to +325°F	-100 to +285°F	-225 to +625°F
9" (225 mm)	-70 to +450°F	-120 to +350°F	-350 to +750°F

## PROBE MOUNTING

The sensing probe may be installed in two general positions, either horizontally or vertically. Horizontal mounting can only be used for on/off point alarm because the process fluid covers the sensing probe with only a small change in level elevation. Vertically mounted probes are used when an output signal proportional to the fluid level or multipoint switching is required. The output signal increases proportionally as the fluid covers the probe. This signal can be used to produce a 4-20 MADC output or to switch setpoints along the length of the probe.

## HORIZONTALLY MOUNTED PROBE

**ON/OFF SWITCHING** - A SMALL CHANGE IN FLUID LEVEL COVERS THE PROBE AND PRODUCES A MAXIMUM SIGNAL.

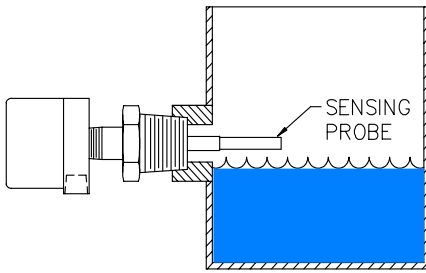

## VERTICALLY MOUNTED SENSING PROBE

**- 4-20 mA TRANSMITTER -**  
A LINEAR SIGNAL INCREASE OCCURS AS THE FLUID LEVEL INCREASES FROM 0% TO 100% ELEVATION AND COVERS PART OF THE SENSING PROBE.

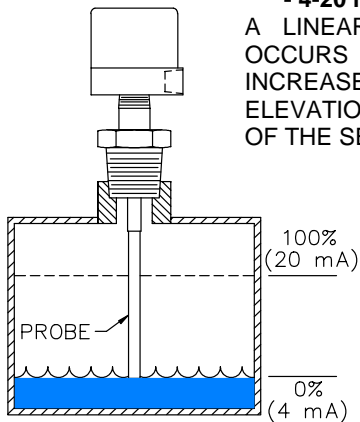

**NOTE:** Also applies to probes which are horizontally mounted through the sidewall but have the sensing rod bent downwards at 90° so as to achieve a vertically mounted result.

## INACTIVE SHIELD USAGE

The sensing probe must sense only the fluid of interest if the application is to be successful. Solids deposits, sediment, etc., must not influence the measurement signal. These deposits usually occur in cavities and other areas where the fluid is stagnated and particles have the opportunity to settle out. A good example of such a cavity is the recess of a flanged nozzle connection. Settled and precipitated material will remain in the nozzle after the fluid level has dropped. A sensing probe entering the vessel through such a nozzle will sense this material and indicate "High Level" even though no liquid is present. The solution to this potential problem is to specify an inactive shield over the portion of the sensing probe which is within the nozzle. An inactive shield consists of a tight fitting metal tube slipped over the sensing rod and welded to the gland. The tube blanks out the settled material on the outside of the tube. It is not sensed because it is not between the sensing probe and its ground reference. The same situation occurs when material builds up on the inner wall of a vessel. An inactive shield long enough to extend out past the maximum buildup is required.

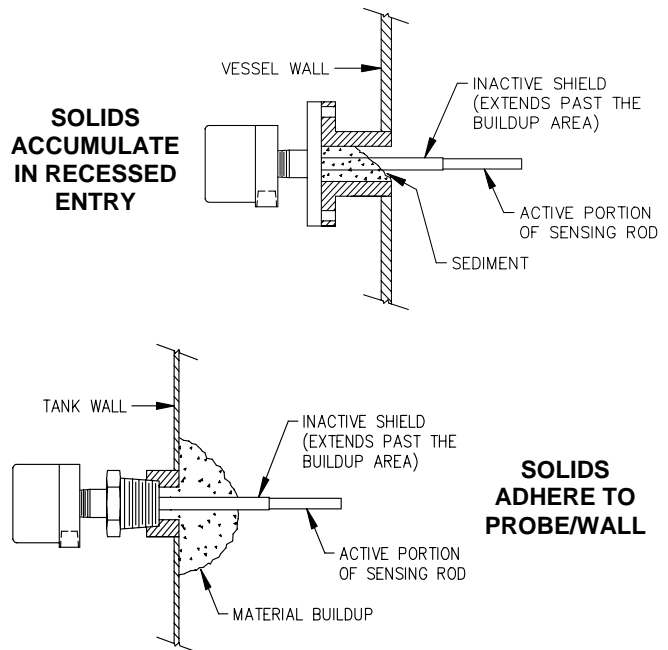

## VISCOUS LIQUIDS SERVICE

Highly viscous and clinging liquids may adhere to a horizontally mounted probe in sufficient quantity to prevent switching after the fluid level drops. A simple solution is to mount the probe at an angle so that clinging liquid collects at the tip, forms droplets, and drips off of the rod. This also minimizes buildup and increases the speed of response.

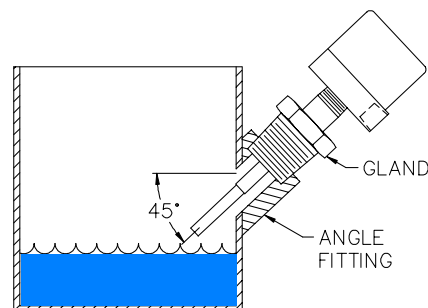

## INTERFACE SERVICE

The interface between two fluids is easily detected by the pulse wave measurement technique. One or both of the fluids must be nonconductive. An interface measurement is accomplished by sensing the average dielectric constant (Dc) along a vertical rod. The upper fluid is normally the nonconductive one and has a lower Dc. Thus the Dc sensed is at a minimum value when the vessel is full of the upper fluid. The lower fluid usually has a high Dc or is conductive. Thus, the Dc is at a maximum value when the vessel is full of the lower fluid. The average Dc sensed by the rod will then vary between these two values depending on the relative amounts of the two fluids contained in the vessel. The ratio of these two amounts determines the interface position and the magnitude of the output signal.

A horizontally mounted probe rod produces an on/off alarm signal as the interface passes its elevation. It simply senses the change in Dc between the two fluids and averaging is not involved.

It is necessary that only one interface position act on a single sensing rod. The measurement is a ratio between two variables and only a single solution is possible. Two or more interfaces involve three or more variables and multiple solutions result. A second interface such as the gas/upper fluid interface must be blanked out so that only the interface of interest is sensed. This is accomplished with an inactive shield in the gas space. The shield covers the sensing rod down to a point that is below the minimum elevation of the top surface of the upper fluid.

Some services, such as an oil skimmer have a small amount of oil floating on top of a large volume of water. These services are accommodated by a float which rides on the top surface of the oil. It carries the sensing probe up and down as the oil thickness varies, and will work under widely varying (50 feet, 15 meters of oil/water) level elevations.

## GRAVITY SEPARATOR

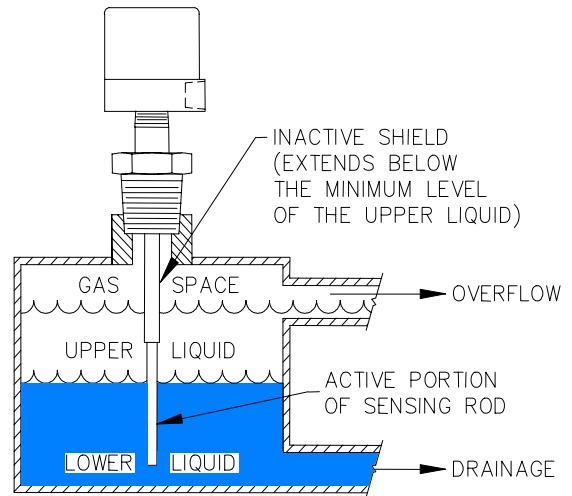

## WASTE OIL SKIMMER

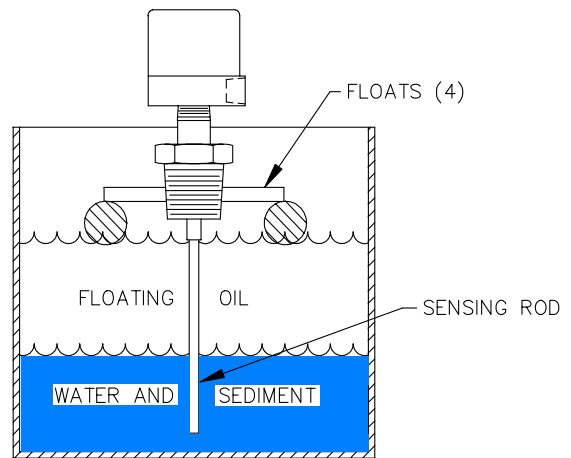

## DUAL SEALED VENTED PROBE GLAND – FOR LETHAL OR TOXIC SERVICE

The secondary seal blocks and diverts process material in the event of a primary seal failure caused by fire, relief valve failure, etc. The process material moves into the cavity and is sent out the vent line to a safe disposal point. This dual seal design is standard on the P55 and P56. It is optional on most other Delta sensing probes.

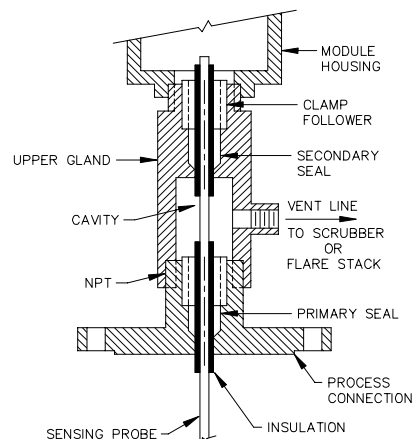

# SELECTING SENSING PROBES FOR GRANULAR SOLIDS AND POWDERS

## APPLICATION

The measurement of solids requires heavier duty and stronger sensing probes than do liquids. The dry particles do not flow as readily as do liquids and can exert high mechanical loadings on the sensing probe. Heavy duty rigid probes are supported by strong insulators such as Delrin, filled plastic, and ceramics. These provide a high resistance to bending, shearing, and shorting. Vertical mounted probes can experience large side loadings and utilize heavy duty cables.

Pulse wave sensing of dry granular solids is usually limited to producing single point alarm switch action. The reason for this common limitation is that small variations in the percentage of moisture in bulk solids will cause very large changes in total material dielectric constant. Moisture variations in particulate solids are very common; they can be caused by atmospheric condensation, absorption, etc. Single point alarm type pulse wave switches will operate over a wide range of dielectric constant variations and are recommended for solids service.

Multipoint switches and proportional transmitters are not normally recommended for most solids applications. However, these modules will do an excellent job if the percentage of moisture does not vary (a rarity). The total amount of moisture is not a consideration as long as it is constant, contained interstitially (not surface moisture) and the material is nonconductive.

The percentage moisture content of most solids varies to some extent. The Dielectric Constant of water is 85 and it is less than 3 for most particulate solids. A proportional transmitter will thus have a level output signal error of 15 to 30% for a 1% change in moisture content.

## 4-20 mA LEVEL TRANSMITTER

The level of solids can, however, be reliably measured by a Model 820 "Kodata" sounding weight level transmitter. These units are equipped with a weight supported by a jacketed stainless steel cable. The 820 lowers the weight until it touches the solids in the silo, and then retracts it. The distance lowered is converted into a 4-20 mA level signal. The signal may be selected as material inage or outage. The 820 can be updated by an automatic timed cycle, by a PLC, computer, or limited to manual pushbutton initiation. Manual update is usually preferred if the level changes slowly, as is common in many plant services. The Model 820 can be part of a system measuring up to 24 silos. It can also be equipped with alarm points, digital bi-directional signals and remote configuring. Refer to: TS-820 for detailed information.

## TYPICAL INSTALLATIONS

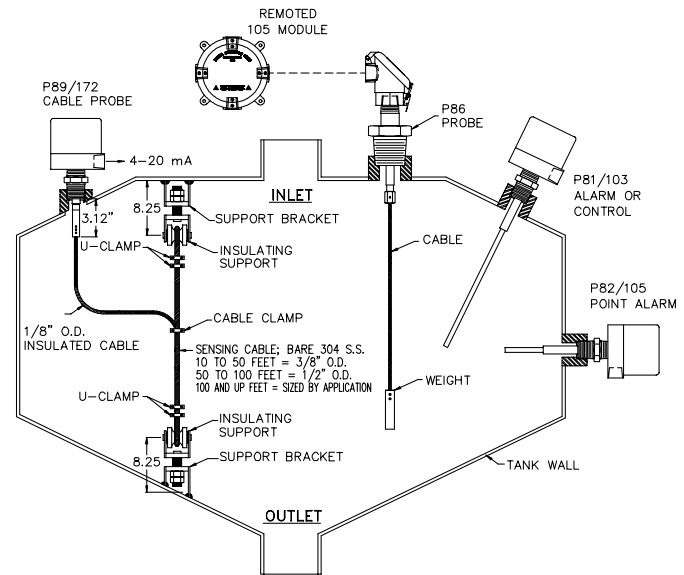

## TRUE DIELECTRIC CONSTANT

Granular solids and powders are composed of particles of material which touch other particles but do not fit together exactly. This results in a vessel that is "full" of a granular solid or powder actually being full of a mixture of the particulate solid material and air. The weight of the particulate solid intermixed with air is called the "Bulk Density". The weight of the material in its voidless solid condition is called the "Solid Density". Pulse wave type instruments detect level by sensing the actual dielectric constant of the space between the sensing probe and the tank wall. This actual value is a resultant of the dielectric constant (Dc) of the particulate solids plus that of the gas which is contained in the voids between particles. The true dielectric constant, "DcT", of the bulk material (suitable for probe selection) is determined as follows: (DcS = density of the voidless solid)

$$DcT = (DcS - 1) \times \frac{\text{BULK DENSITY}}{\text{SOLID DENSITY}} + 1.0$$

## INSTALLATION DESIGN TIPS

- (1) Flexible cable probes must have a bottom tie-down if high velocity air currents are present.
- (2) Sensing probes should be located so that blown-in material does not unevenly pile on them.
- (3) Alarm action modules should be equipped with adjustable time delays to stop false switching due to the momentary presence of material.
- (4) Vented long-term storage bins can "breathe" in and condense enough water vapor to cause significant transmitter signal errors. This does not normally disrupt switch action units with horizontally mounted sensing probes.

# DIELECTRIC CONSTANTS (ESU) OF VARIOUS INDUSTRIAL MATERIALS

## NONCONDUCTIVE LIQUIDS

The values shown are for pure process materials @ 77°F (25°C) unless otherwise noted. The values shown increase at lower temperatures and decrease at higher temperatures. These variations are usually less than ±5% between 0°F and 150°F (-18 to 65°C). Dc values are available from reference books and the material's manufacturer. **NOTE:** Material containing 15% or more water is usually conductive.

Acetal	3.6	Butylacetate	5.1	Diphenylamine (125°F)	3.3	Isopropylether	3.9
Acetaldehyde	22.0	Butylamine	5.4	Dipropylamine	2.9	Isosafrol	3.4
Acetanilide	2.9	Butyric Acid	2.8	Dioxane	2.2	Isovaleric Acid	2.7
Acetamide	4.0	Camphene	2.7	Dipentene	2.3	Jet Fuel (JP4)	1.7
Acetate	1.3	Camphoric Imide (480°F)	5.5	Diphenyl Ether	3.9	Kerosene	1.8
Acetic Acid (68°F)	6.2	Caprolactam Monomer	1.7	Dodecane	2.0	Lactic Acid	19.4
Acetic Anhydride	20.0	Caprolactam (180°F)	13.1	Dodecanol	6.5	Lead Oleate	3.2
Acetone	20.7	Caprylic Acid	3.2	Dowtherm (Heating Fluid)	3.4	Limonene	2.3
Acetonitrile	37.5	Carbon Dioxide (Press)	1.6	Epichlorohydrin	22.7	Linoleic Acid	2.9
Acetyl Acetone	25.0	Carbon Disulfide	2.6	Ethanethiolic Acid	13.0	Longne	10.0
Acetyl Bromide	16.5	Carbon Tetrachloride	2.2	Ethanol (-76°F)	41.0	Maleic Anhydride	51.0
Acetyl Chloride	15.8	Carvol	11.2	Ethanol (Ethyl alcohol)	24.3	Mannitol	3.0
Air (Dry gas)	1.0005	Carvone	11.0	Ethoxytoluene	3.9	Margarine (105°F)	2.9
Aliphatic Amine	7.2	Casein	6.1	Ethyl Acetate	6.0	Menthol	4.0
Alkyd	3.2	Cetyl Iodide	3.3	Ethyl Alcohol	24.3	Menthone	8.8
Allyl Alcohol	22.0	Chloral	4.9	Ethyl Benzene	2.5	Menthonol	2.1
Allyl Chloride	8.2	Chlorine (-58°F)	2.1	Ethyl Bromide	4.9	Mesitylene	2.4
Allyl Isothiocyanate	17.2	Chlorine (Press)	1.9	Ethyl Ether	4.2	Methane (-280°F)	1.7
Aluminum Hydroxide	5.4	Chloroacetic acid	2.1	Ethyl Formate	8.4	Methelene Chloride (40°F)	8.4
Aluminum Oleate	2.4	Chloroaniline (-M)	13.5	Ethyl Mercaptan	8.0	Methyl Alcohol (Wood Alcohol)	32.6
Ammonia (Press)	16.5	Chlorobenzene	5.6	Ethyl Nitrate	19.7	Methyl Acetate	7.3
Ammonia (-30°F)	22.0	Chloroheptane	5.5	Ethyl Oleate	3.2	Methyl Butyrate	5.6
Ammonia (68°F)	15.5	Chloroform	4.8	Ethylene Chloride	10.5	Methyl Cyclopentane	2.0
Amyl Acetate	5.0	Chlorophenol	8.2	Ethylene Diamine	16.0	Methyl Ether	5.0
Amyl Alcohol	15.8	Chlorotoluene	4.5	Ethylene Glycol	37.0	Methyl Ethyl Ketone	18.4
Amyl Alcohol (140°F)	11.2	Chocolate (100°F)	2.3	Fats, Animal	2.0	Methyl Formate	8.5
Amylamine	4.6	Chorine	1.7	Ferric Oleate	2.6	Methyl Heptanol	6.3
Amyl Benzoate	5.1	CIS-3-Hexane	2.1	Ferrous Sulfate	14.2	Methyl Mercaptain	7.6
Amyl Ether	3.1	Copper Oleate	11.0	Fluorine (-332°F)	1.5	Methyl Nitrate	23.0
Amyl Formate	5.7	Cresol (-M)	5.0	Fluorotoluene	4.0	Methyl Propanol	10.9
Amylene	2.0	Cresol (-O)	11.5	Formaldehyde	2.5	Methyl Propionate	5.4
Amylmercaptan	4.7	Cumene	4.4	Formamide	84.0	Methyl Salicylate	9.0
Anhydrite	4.9	Cyanoacetic Acid	33.0	Formic Acid	58.5	Methyl Sulfide	6.2
Aniline	7.3	Cyanogen	2.6	Freon 12	2.4	Methyl Thiocyanate	35.9
Aniline (212°F)	5.5	Cyclohexane	18.3	Furan	3.0	Methylamine	9.4
Anisole	4.3	Cyclohexanol	15.0	Fufural	42.0	Methylaniline (-N)	6.0
Antimony Pentachloride	3.2	Cyclohexanone	18.2	Furfuraldehyde	41.9	Methylbenzylamine	4.4
Antimony Trichloride	33.0	Cyclohexene	18.3	Gasoline	2.0	Methylbutadiene	2.1
Argon, Liquified (-376°F)	1.5	Cyclohexylphenol	5.0	Glue (Animal) 3.6% H <sub>2</sub> O	2.6	Methylcyclohexane	2.3
Arsenic Trichloride	12.4	Cyclopentane	2.0	Glycerine	47.0	Methylsulfate	42.0
Arsine (-58°F)	2.7	Cymene	2.3	Glycerol	42.5	Moca	8.8
Arsine (-148°F)	2.5	Decane	2.0	Glycol	41.2	Monochlorethane	10.0
Asphalt (400°F)	3.7	Decanol	8.1	Heptane	1.9	Monopalmitim (176°F)	5.1
Azoxybenzene	5.3	Dichlorophenal	4.8	Heptanol	6.1	Nanene (50°F)	2.0
Benzal Chloride	6.9	Diallyl Sulfide	4.9	Heptene (1-)	2.1	Naptha (Refinery cut)	2.0
Benzene	2.3	Dibenzylamine	3.6	Heptonic Acid	2.9	Napthalene	2.5
Benzene (275°F)	2.1	Dibromobenzene	8.8	Heptyl Alcohol	6.7	Nitroaniline (194°F)	34.0
Benzil	15.5	Diethylphthalate	6.4	Hexachlorobutadiene	2.6	Nitrobenzene	34.9
Benzyl Alcohol	13.0	Dicaphor	3.7	Hexane (-N)	1.9	Nitroglycerine	19.0
Benzyl Amine	4.6	Dichloroacetic Acid	8.2	Hexanol	13.3	Nitrogen (-336°F)	1.5
Benzyl Chloride	6.9	Dichlorobenzene	2.8	Hexanone	14.6	Nitromethane	39.4
Benzyl Cyanide	18.3	Dichloroethane	10.3	Hexene	2.0	Nitrotoluene (-O)	25.0
Benzyl Salicylate	4.1	Diebenzylamine	3.6	Hydrazine	52.0	Nitrous Oxide	1.6
Benzylamine	5.0	Diethyl Carbonate	2.8	Hydrocyanic Acid	2.3	Nonane	2.0
Boron Bromide	2.6	Diethyldisulfide	16.0	Hydrogen Bromide (-120°F)	3.8	Nylon (Molten +0.14% H <sub>2</sub> O)	1.9
Bromal	7.6	Diethyl Ketone	16.0	Hydrogen Cyanide	95.4	Octane (1.95)	1.9
Bromine	3.1	Diethyl Malonate	7.9	Hydrogen Sulfur (Press)	5.8	Octanone	10.3
Bromoaniline	13.0	Diethyl Oxalate	8.2	Indanol	7.8	Octene	2.0
Bromoacetyl Bromine	12.6	Diethylamine	3.7	Ink(Printing)	3.0	Octyl Alcohol	3.4
Bromoform	4.4	Diisobutylamine	2.7	Iodethane	7.8	Oil, Almond	2.8
Bromotoluene	5.1	Dimethyl Phthalate	8.5	Iodine (Melted, 250°F)	18.0	Oil, Cable	2.2
Butane (Press)	1.3	Dimethyl Succinate	5.1	Ionone	10.0	Oil, Castol	4.7
Butanol	17.8	Dimethyl Sulfate	55.0	Isoamyl Chloride	6.4	Oil, Castol Hydrogenated	10.3
Butyl Acetate	5.1	Dimethyl Sulfide	6.3	Isobutyl Alcohol	18.7	Oil, Castor	2.6
Butyl Alcohol (-N)	7.8	Dimethylamine	5.3	Isobutyl Amine	4.5	Oil, Cotton Seed	2.7
Butyl Amine	5.4	Dimethylaniline	4.9	Isobutyl Nitrate	11.9	Oil, Crisco Cooking (130°F)	2.2
Butyl Anhydride	12.0	Dimylamine	2.5	sobutyric Acid	2.6	Oil, Crude Petroleum	2.1
Butyl Chloride	9.6	Dinitrobenzene	2.8	Isoprene	2.1	Oil, Fuel	2.2
Butyl Ether	3.1	Dipentene	2.3	Isopropyl Alcohol	18.3	Oil, Lemon	2.3
Butyl Oleate	4.0	Diphenyl	2.5	Isopropylamine	5.5	Oil, Linseed	3.4

**NONCONDUCTIVE LIQUIDS (Continued)**

Oil, Lubricating (10W40)	2.2	Stannic Chloride	3.2
Oil, Mineral	2.1	Stearic Acid (160°F)	2.3
Oil, Olive	3.1	Stibine (-58°F)	2.5
Oil, Paraffin	2.2	Styrene	2.4
Oil, Peanut	3.0	Sulfur (Molten, 244°F)	3.5
Oil, Pyranol	5.3	Succinic Acid	2.4
Oil, Safrol	3.1	Sulfur Dioxide (Press)	14.0
Oil, Silicon	2.7	Sulfur Trioxide	3.6
Oil, Sperm	3.2	Sulfuryl Chloride	10.0
Oil, Transformer	2.2	Tallowamine (Hydrogenated)	2.6
Oil, Turpentine	2.2	Tartaric Acid	6.0
Oleic Acid	2.5	Terpene Resin	2.3
Palmitic Acid	2.3	Terpineol	2.8
Parafomaldehyde	3.8	Tetradecanol (100°F)	4.7
Paraldehyde	13.9	Tetraethyl Silicate	4.1
Pentachloroethane	3.7	Tetralone (Crude)	4.9
Pentadiene	2.3	Tetramethyl Silicate	6.0
Pentane (-N)	1.8	Thioacetic Acid	2.3
Pentanol	13.9	Thionyl Chloride	9.3
Pentanone	15.4	Thiophene	2.8
Pentene	2.1	Tin Tetrachloride	2.9
Phenol Isobuthyl	14.9	Toluene	2.4
Phenol	4.3	Toluidine	3.0
Phenyl Acetate	6.9	Tolunitrile	18.8
Phenyl Ethanol	13.0	Tributylphosphate	8.0
Phenyl Propane (-1)	2.7	Trichloroacetic Acid	5.1
Phenol Ether	9.8	Trichloroethylene	3.4
Phenyl Ethylene	2.4	Tricresyl Phosphate	6.9
Phenol (50°F)	4.3	Triethyl Aluminum	2.9
Phosgene	4.3	Trifluorotoluene	9.2
Phosphene (-76°F)	2.5	Triethylamine	2.4
Phosphorus Trichloride	3.4	Trimethyl Borate	8.2
Photo-Resist (Circuit Boards)	2.4	Trimethylamine	2.5
Phthalide	39.0	Trinitrobenzene	2.2
Pinacone	7.4	Triolein	3.2
Pinene	2.7	Tripalmitin (140°F)	2.9
Polycarbonate Resin	1.2	Turpentine	2.2
Polyester Resin	5.5	Undecane	2.0
Polyglycol	9.4	Urea	3.5
Polyol	49.5	Urethane	3.2
Propane (Press)	1.6	Valeric Acid	2.6
Propanol	20.1	Vanadium Tetrachloride	3.0
Propene	1.9	Vepatrol	4.5
Propionaldehyde	18.9	Vinyl Ether	3.9
Propionic Acid	3.1	Vinyl Formal	3.0
Propyl Alcohol	21.8	Vinyl Prolidone	21.2
Propyl Benzene	2.4	Water (32°F)	88.0
Propyl Ether	3.3	Water (68°F)	80.0
Ptalic	31.0	Water (212°F)	48.0
Pulezone	9.7	Water (390°F)	34.5
Pyrazine	2.8	Water (Steam) (68°F)	1.008
Pyridine	12.5	Wax, Paraffin (250°F)	1.9
Pyrrrole	7.5	Wax, Petroleum (200°F)	3.0
Quinoline	9.0	Xylene (-M)	2.4
Quinone	3.7	Xylene (-O)	2.6
Safrol	3.1	Xylenol	3.9
Salicylaldehyde	13.9	Xylitol	40.0
Selenium (480°F)	5.4	Xylol	2.3
Silicon Tetrachloride	2.4	Xylidine	5.0
Sodium Sulphate	2.7	Zinc Carbonate	5.0
Sorbitol	67.0	Zirconium Tetrachloride	5.0

**NONCONDUCTIVE SOLIDS**

The materials listed below are pure and in a voidless solid condition unless noted. Correct for actual bulk density of material being modeled.

Acetic Acid (36°F)	4.1	Methyl Methacrylate	3.0
ABS Plastic (Ground)	2.4	Mica	7.0
Acetamide	4.0	Milk (Dry Powder)	1.8
Alumina	8.1	Napthalene	2.5
Aluminum Chloride	7.0	Nylon pellets	1.1
Ammonium Chloride	7.0	Paper (Dry)	2.0
Arsenic (Powder)	2.2	Paraffin	2.2
Asphalt	2.7	Peanuts (Fresh)	27.4
Bakelite	5.0	Peanuts (Roasted)	2.0
Baking Soda (Ground)	1.8	Phenol (50°F)	4.3
Barium Sulfate	11.4	Phenol Formaldehyde	4.5
Barley Malt (Ground)	2.6	Phosphate Rock (Ground)	4.2
Bauxite Ore (Ground)	3.0	Phosphorus	3.6
Bentonite	7.5	Pitch (Ground Pine)	4.3
Bisphenol (Powder)	1.9	Plaster (Powder)	2.5
Calcite	8.0	Polyester Resin	2.8
Calcium Carbonate	9.1	Polyethylene	2.2
Candy (Reese's Pieces)	2.1	Polyethylene (Chips)	6.6
Carnauba Wax	2.9	Polyethylene (Fluff)	1.5
Casein	6.1	Polyimide	2.8
Cellulose Acetate	3.6	Polystyrene (Pellets)	1.7
Cellulose	4.0	Polyvinyl Chloride	3.4
Cement, Portland (Ground)	2.3	Porcelain	8.0
Cement, Ballmill feed (to 1")	2.7	Potassium Nitrate	5.9
Cement, Clinker	2.7	Potatoes (Dry Powder)	1.9
Cereal (Flakes)	3.0	PTFE	2.0
Chocolate	2.3	Quartz	4.2
Clay	7.4	Rasins (Sun Dried)	4.8
Clay (Ground)	2.5	Refractory (Ground)	1.8
Coal (Bituminous, crushed)	7.5	Rice (Dry Grains)	3.5
Coal (Coked, particles)	1.6	Rubber (Foam)	1.1
Cocoa (Ground)	1.8	Rubber (Hard)	2.8
Cocoa Beans	2.4	Rubber, Chlorinated	3.0
Coffee (Ground)	1.5	Sand (Particles)	2.2
Coffee Beans (Roasted)	4.4	Sand (Reclaimed Foundry)	4.0
Corderite	4.5	Slate	7.0
Corn (Dry Grains)	4.6	Soap (Bar)	6.0
Corn Cobs (Ground)	2.5	Soap (Powder)	1.3
Corn Starch (Flakes)	3.6	Sodium Bicarb (Baking Soda)	1.8
Cupric Oxide	18.1	Sodium Carbonate	5.3
Diatomaceous Earth (Grd)	2.7	Sodium Chloride (Ground)	3.4
Dolomite	6.8	Soy Beans	2.6
Epoxy Resin (Cast.)	3.6	Soy Beans (Meal)	3.1
Ethyl Cellulose	3.3	Steatite	6.5
Glass (Cullet)	2.5	Sugar (Granulated)	3.0
Glass (Silica)	3.8	Sulphur	3.4
Gypsum	2.8	Titanium Dioxide (Powder)	2.4
Herbicide (Monsanto Roundup)	1.9	Urea	3.5
Indigo Dye	1.7	Urethane	6.5
Iodine (Crystals)	4.0	Vinylidene Chloride	3.5
Iron Ore (2% water)	10.2	Wax, Bees	2.7
Iron Ore	5.2	Wax (Carnuba)	2.9
Kynar (PVDF)	2.0	Wax, Paraffin	2.2
Lead Acetate	2.5	Wheat (Dry Grains)	2.0
Lead Oxide (Ground)	3.6	Wheat Flour (Dry Powder)	3.0
Lime	10.9	Wood (Dry Chips)	2.0
Lime (Ground)	2.6	Wood (Dry Pulp)	4.8
Magnesium Oxide	9.7	Wood (Dry Sawdust)	1.6
Melamine	5.5	Zinc Sulfide	8.2



**DELTA CONTROLS**  
CORPORATION

*Engineered Sensors - For Difficult Services*

585 Fortson Street  
Shreveport, La. 71107 - USA  
Ph: +1(318) 424-8471  
Fax: +1(318) 425-2421  
E-mail: sales@deltacnt.com  
Web: www.deltacnt.com