

# TYPE 626 FIREWATER FLOW DETECTION SWITCH

Detects a Single Nozzle Discharge in 2" To 6" Line Sizes  
Used in Offshore Seawater Deluge Systems

TS 626

- Detects a Single Nozzle Discharging
- No Pressure Loss at High Flow Rates
- Full Open Bore – No Pipeline Restriction
- Proven Reliable for Over 15 Years
- Magnetic Flow Target to Switch Coupling
- Flow Powered – No Other Power Required
- Alloy Materials Suitable for Seawater
- Insensitive to Seawater Deposits

## APPLICATION

The Delta Controls Model 626 is a target actuated flow switch, it is equipped with a body that fits into and becomes part of the pipeline. It is used to detect very low flow rates in offshore deluge firewater piping systems.

The Model 626 is equipped with a “fitted” target that nearly fills the inside area of the in-line pipeline body under no flow conditions. The target is the “full swing” type. It rotates back 90° to rest against the inside of the pipeline when the flow rate exceeds the calibrated alarm activation flow rate.

The target has been “cupped” and “fitted” so that it fills the inside pipe area and is flush against the interior curve of the pipeline during higher flow rates. Only the thin edge of the target, plus its support block, is in the flow. The inside area of the pipeline is not restricted and the result is a full pipe size open bore. This design allows extremely high flow velocities without damage or pressure losses. Even so, the 626 can actuate at the very low flow rate which occurs when a single nozzle has begun to operate.

The Delta Controls Model 626 has been used to detect seawater flow in deluge fire systems for over 15 years. It has been used on offshore oil platforms in the North Sea, the Gulf of Mexico, the Persian Gulf; as well as near Australia, Indonesia, and Russia. It has also seen service on drill ships and floating production facilities.



MODEL 626 FOR A 4" SIZE  
FIREWATER FLOW LINE

## OPERATING SCHEMATIC

Connection of the target to the output switch is done magnetically. A heavy-duty solid sealing tube separates the seawater from the switch mechanism. Failures which can occur due to seal, diaphragm, and bellows leaks are eliminated.

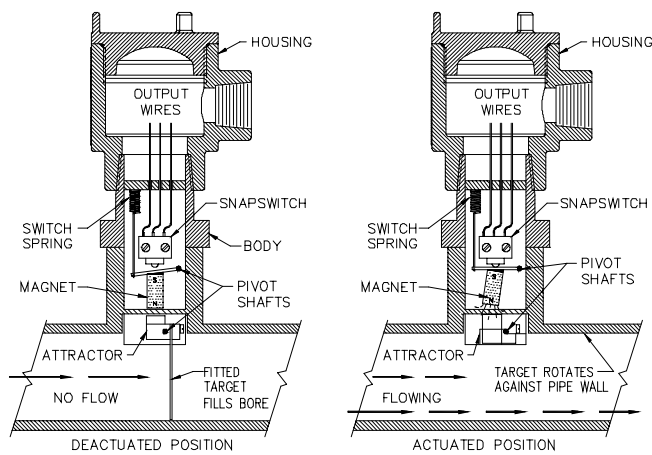

**DELTA CONTROLS CORP**

# MODEL NUMBERING SYSTEM

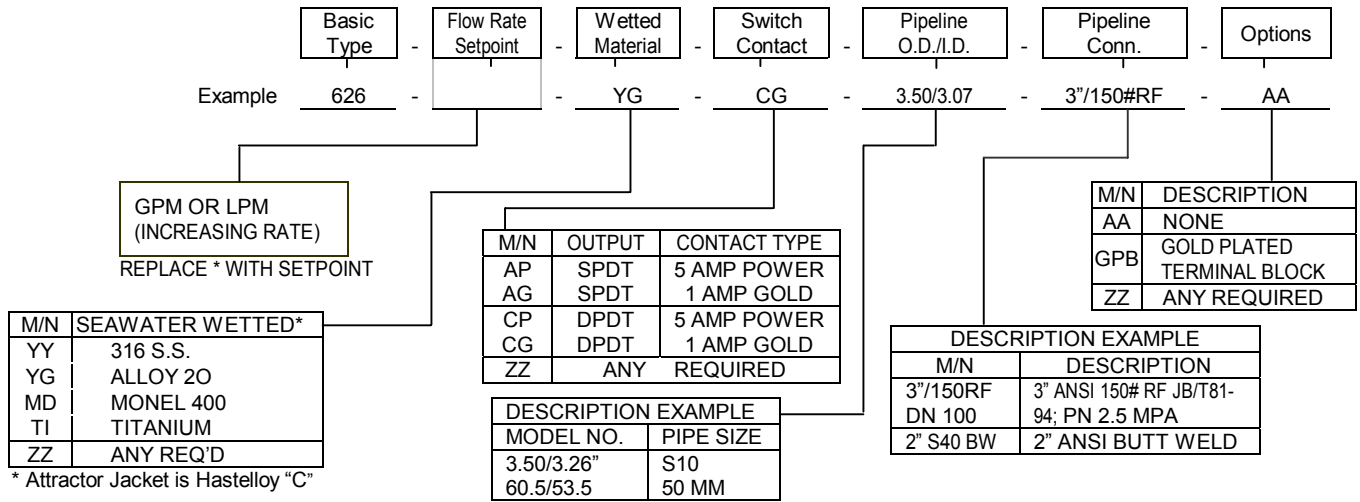

## MINIMUM RECOMMENDED FLOW SWITCH RATE

SWITCH ACTION * AT FLOW RATE	PIPE SIZE - SHOWN FOR ANSI SCHEDULE 40							
	2"		3"		4"		6"	
	GPM	LPM	GPM	LPM	GPM	LPM	GPM	LPM
ACTUATE	3.0	11.4	4.8	18.2	8.5	32.1	17.5	66.2
DEACTUATE	1.4	5.3	2.2	8.3	3.8	14.4	7.9	30.0

- \* (1) Switch Point is normally selected to detect that a single nozzle is discharging; but it can be calibrated for higher flow rates as required
- (2) Based on seawater at STP; 77°(25°C) and 1 Bar

## BASIC SPECIFICATIONS

**Actuation Flow Rate:** Calibrated to within 10% closer optional

**Output Switch:** 1 or 2 Micro style

**Switch Operating:** -50 to +220°F (-45 to 105°C)

**Switch Contact Configuration:** SPDT or DPDT

**Switch Contact Material & Rating:**

Metal oxide; 5 amp at 240 VAC or 24 VDC  
Gold; 1 amp at 24 VDC (for IS use)

**Output Switch Failsafe Position:** Spring loaded inside conduit connection housing

**Terminals:** Copper nickel-plated; clamp type; wire up to 12 AWG (2.1MM)

**Housing:** 304 S.S., O-Ring sealed; 3 / 4" NPT or 20mm; Class 1, Division 1, Groups BCD & 4X, CSA, NRTL/C; IP67, CE

**Body Gasket:** Metal spiral; PTFE Teflon seal

**Studs and Bolts:** A-193BB, A-194; stainless steel

**Options:** Any modification or change required by the service or installation

Application Data: See AN-62201

## OUTLINE DIMENSIONS

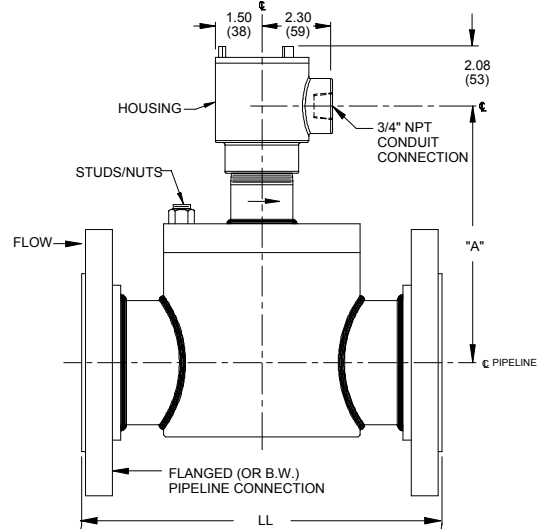

PIPELINE (ANSI SHOWN)*	PIPELINE CONNECTION	PIPELINE CONNECTION			
		150# RF		BUTTWELD	
SIZE	DIM	INCH	MM	INCH	MM
2"	"LL"	10.0	254	9.6	244
	"A"	6.0	152	6.0	152
3"	"LL"	12.0	305	11.6	245
	"A"	7.6	193	7.6	193
4"	"LL"	14.0	356	13.6	345
	"A"	8.8	224	8.8	224
6"	"LL"	17.0	432	16.6	422
	"A"	8.4	213	8.4	213

\* METRIC PIPE AND OTHER SIZES ARE OPTIONAL

**DELTA CONTROLS CORP**

Engineered Sensors – For Difficult Services

585 Fortson Street  
Shreveport, La. 71107 - USA



Voice: 318-424-8471

Fax: 318-425-2421

E-mail: delta@deltacnt.com

Web Site: http://www.deltacnt.com