

MODEL 552 WITH MODULAR ELECTRONICS

FEATURES

- General Purpose Pressure/Level Service
- Separate Electronics Module And Sensor
- Heavy Duty Rugged Body
- Measures Liquid Level In Pressurized Tanks
- Electronics Module Can Be Remoted
- Ranges From 12 Inches Water To 3000 PSI
- Zero & Span Pots For Field Recalibration
- Spark & Voltage Surge Protection
- Optional Selectable Dampening
- Optional LCD Display (in Engineering Units)
- Optional Integral Power Supply Module
- Optional Integral Alarm Module(s)
- Maintenance Free Operation

SPECIFICATIONS

Technology: Silicon Strain gage.

Supply Power:

13 to 35 VDC 2 Wire Loop Powered.

Output: 4-20 mA DC, Isolated, Intrinsically Safe

Loop Impedance:

550 Ω at 24 VDC. 1100 Ω at 35 VDC

Adjustments:

Span from 30% to 100% of sensor range.
Zero to 30% basic and to 80% optionally,
non-interactive.

Over Pressure:

2X Range (35 PSI min) without damage
3X Range (1000 PSI min) without rupture

Temperature Range:

-20 to +220°F (Process, short time)
-20 to +180°F (Electronics)
30 to +130°F (Compensated)

Accuracy: $\pm 0.25\%$ F.S. or better

Thermal Error: $\pm 0.02\%$ F.S./°F Maximum

Barometric Effect: None

OPTIONAL FEATURES

Dampening: Selectable 0.1 to 22 seconds

Indicator:

Large LCD display (in Engineering Units)
DC Power Supply*: Integral VAC to 24 VDC.

Alarm Module(s)*: Integral 5 amp SPDT.

TPC Corrector:

Level Measurement In Pressurized Tanks

* Not third party listed



DESCRIPTION

The Model 552 Pressure Transmitter consists of a potted electronic module and a modular pressure sensor assembly packaged as an integral unit. The sensor includes an oil filled 316-L S.S. or platinum diaphragm which isolates the strain gage bridge from the process liquid or gas. The back of the sensor is usually vented to atmosphere to compensate for barometric pressure changes. The electronics module is potted in a dual system of silicon rubber and epoxy to protect against moisture, corrosion, and vibration.

The 552 is commonly used as a liquid level transmitter in tanks. The pressure at the bottom of a vented tank containing a liquid is linearly proportional to the height and density of the liquid. The TPC corrector option is required for pressurized tanks.

MODEL NUMBERING SYSTEM

PRESSURE/LEVEL TRANSMITTER WITH MODULAR ELECTRONICS

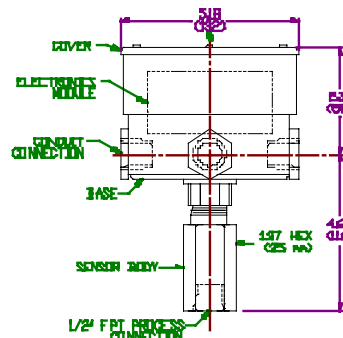
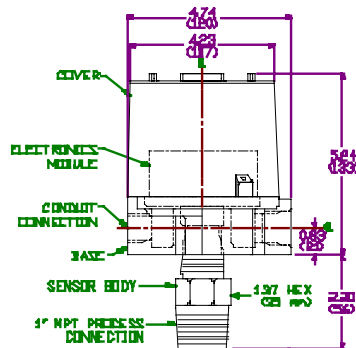
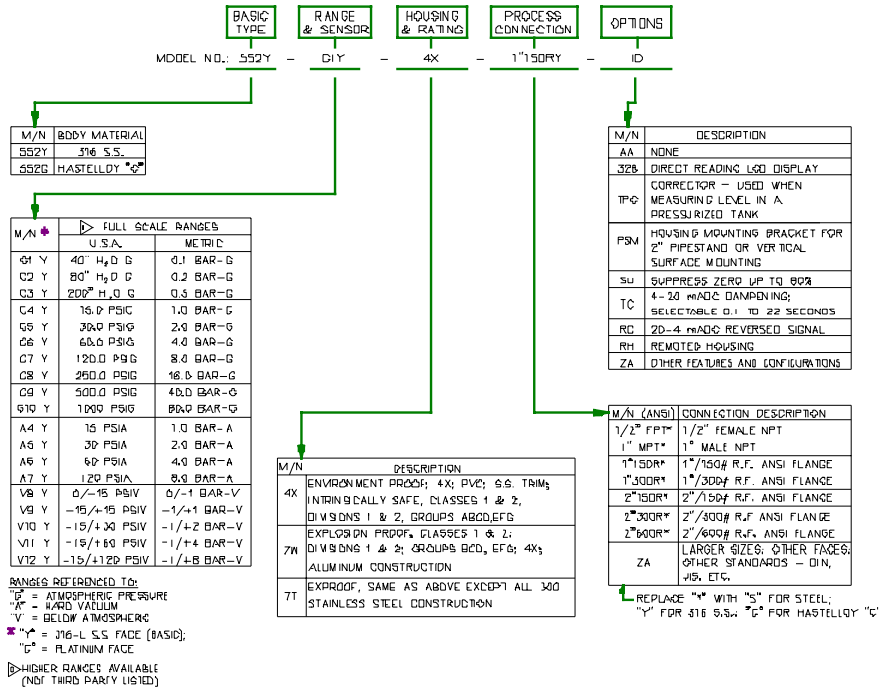

THIRD PARTY APPROVALS

CSA (Canada)
 NRTL/C (USA)
 Intrinsically Safe
 Explosion proof
 Environment proof
 ISO 9001 Quality System

**MADE IN THE USA
 BY
 DELTA CONTROLS**

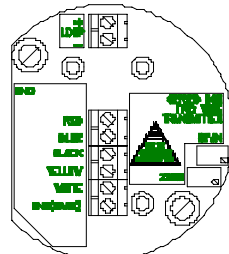

DELTA CONTROLS Corporation
 585 FORTSON STREET
 SHREVEPORT, LA. 71107 - USA
 PHONE: 318-424-8471 FAX: 318-425-2421



e-mail: delta@deltacnt.com Web Site: http://www.deltacnt.com